



Designation: C230/C230M – 23

# Standard Specification for Flow Table for Use in Tests of Hydraulic Cement<sup>1</sup>

This standard is issued under the fixed designation C230/C230M; the number immediately following the designation indicates the year of original adoption or, in the case of revision, the year of last revision. A number in parentheses indicates the year of last reapproval. A superscript epsilon ( $\epsilon$ ) indicates an editorial change since the last revision or reapproval.

## 1. Scope\*

1.1 This specification covers requirements for the flow table and accessory apparatus (Note 1) used in making flow tests for consistency of mortars in tests of hydraulic cement, such as but not limited to Test Method C1437.

NOTE 1—To help clarify the design of the flow table and accessory apparatus see the drawing in Fig. 1 [Fig. 2]. This drawing is for informational purposes only. See Fig. 3 of the flow table and accessory apparatus as a reference for further clarification.

1.2 The values stated in either SI units or inch-pound units are to be regarded separately as standard. The values stated in each system are not necessarily exact equivalents; therefore, to ensure conformance with the standard, each system shall be used independently of the other, and values from the two systems shall not be combined. It is permissible to use an inch-pound caliper and mold with a SI flow table or a SI caliper and mold with an inch-pound flow table. It is not permissible to mix a SI mold with an inch-pound caliper or an inch-pound mold with a SI caliper.

1.3 *This standard does not purport to address all of the safety concerns, if any, associated with its use. It is the responsibility of the user of this standard to establish appropriate safety, health, and environmental practices and determine the applicability of regulatory limitations prior to use.*

1.4 *This international standard was developed in accordance with internationally recognized principles on standardization established in the Decision on Principles for the Development of International Standards, Guides and Recommendations issued by the World Trade Organization Technical Barriers to Trade (TBT) Committee.*

## 2. Referenced Documents

2.1 *ASTM Standards:*<sup>2</sup>

C125 Terminology Relating to Concrete and Concrete Aggregates

<sup>1</sup> This specification is under the jurisdiction of ASTM Committee C01 on Cement and is the direct responsibility of Subcommittee C01.22 on Workability.

Current edition approved April 1, 2023. Published May 2023. Originally approved in 1949. Last previous edition approved in 2021 as C230/C230M – 21. DOI: 10.1520/C0230\_C0230M-23.

<sup>2</sup> For referenced ASTM standards, visit the ASTM website, www.astm.org, or contact ASTM Customer Service at service@astm.org. For *Annual Book of ASTM Standards* volume information, refer to the standard's Document Summary page on the ASTM website.

C219 Terminology Relating to Hydraulic and Other Inorganic Cements

C1437 Test Method for Flow of Hydraulic Cement Mortar

## 3. Terminology

3.1 *Definitions:*

3.1.1 The terms in this specification are defined in Terminology C125 and Terminology C219.

## 4. Flow Table and Frame

4.1 The flow table apparatus shall consist of an integrally cast rigid iron frame and a circular rigid table top  $10 \pm 0.1$  in. [ $255 \pm 2.5$  mm] in diameter, with a shaft attached perpendicular to the table top by means of a screw thread. The table top and shaft with contact shoulder shall be mounted on a frame in such a manner that it can be raised and dropped vertically through the specified height of  $0.500 \pm 0.005$  in. [ $12.7 \pm 0.13$  mm] for new tables and of  $0.500 \pm 0.015$  in. [ $12.7 \pm 0.38$  mm] for tables in use, by means of a rotated cam. The table top shall have a fine machined plane surface, free of blowholes and surface defects. The top shall be scribed with eight equidistant lines extending from the outside circumference toward the center of the table, ending  $2\frac{3}{8}$  in. [60 mm] from the center. Each line shall end with a scribed arc,  $\frac{1}{4}$  in. [6 mm] long, whose center point is the center of the table top with a radius of  $2\frac{3}{8}$  in. [59.5 mm]. The scribe lines shall be made with a  $60^\circ$  tool to a depth of 0.01 in. [0.25 mm]. The table top shall be of cast brass or bronze having a Rockwell hardness number not less than 25 HRB with an edge thickness of 0.3 in. [7.5 mm], and shall have six integral radial stiffening ribs. The table top and attached shaft shall weigh  $9 \pm 0.1$  lb [ $4.08 \pm 0.05$  kg] and the weight shall be symmetrical around the center of the shaft.

4.2 The cam and vertical shaft shall be of medium carbon machinery steel, hardened on the end of the shaft contacting the cam and the tip of the cam contacting the shaft. The shaft shall be straight and the difference between the diameter of the shaft and the diameter of the bore of the frame shall be not less than 0.002 in. [0.05 mm] and not more than 0.003 in. [0.08 mm] for new tables and shall be maintained at 0.002 to 0.010 in. [0.05 to 0.25 mm] for tables in use. The end of the shaft shall not fall upon the cam at the end of the drop, but shall make contact with the cam not less than  $120^\circ$  from the point of drop. The face of the cam shall be a smooth spiraled curve of

\*A Summary of Changes section appears at the end of this standard

uniformly increasing radius from ½ to 1¼ in. [13 to 32 mm] in 360° and there shall be no appreciable jar as the shaft comes into contact with the cam. The cam shall be so located and the contact faces of the cam and shaft shall be such that the table does not rotate more than one revolution in 25 drops. The surfaces of the frame and of the table that come into contact at the end of the drop shall be maintained smooth, plane, and horizontal and parallel with the upper surface of the table and shall make continuous contact over a full 360°.

4.3 The supporting frame of the flow table shall be integrally cast of fine-grained, high-grade cast iron. The frame casting shall have three integral stiffening ribs extending the full height of the frame and located 120° apart. The top of the frame shall be chilled to a depth of approximately ¼ in. [6 mm], and the face shall be ground and lapped square with the bore to give 360° contact with the shaft shoulder. The underside of the base of the frame shall be ground to secure a complete contact with the steel plate beneath.

4.4 The flow table shall be driven by a motor (Note 2), connected to the cam shaft through an enclosed worm gear speed reducer and flexible coupling. The speed of the cam shaft shall be approximately 100 r/min. The motor drive mechanism shall not be fastened or mounted on the table base plate or frame.

NOTE 2—A ½-hp [40 W] motor has been found adequate.

4.5 The performance of a flow table shall be considered satisfactory if, in verification tests, the table gives a flow value that does not differ by more than five percentage points from flow values obtained with a suitable verification material (see Note 3).<sup>3,4</sup> Perform the verification at least every 2½ years.

NOTE 3—Some causes of and solutions to unsatisfactory performance of the flow table may be found in the section on flow tables in the *ASTM Manual of Cement Testing*.

## 5. Flow Table Mounting

5.1 The flow table frame shall be tightly bolted to a cast iron or steel plate at least 1 in. [25 mm] thick and 10 in. [250 mm] square. The top surface of this plate shall be machined to a smooth plane surface. The plate shall be anchored to the top of a concrete pedestal by four ½-in. [13 mm] bolts that pass through the plate and are imbedded at least 6 in. [150 mm] in the pedestal. The pedestal shall be cast inverted on the base plate. A positive contact between the base plate and the pedestal shall be obtained at all points. No nuts or other such leveling devices shall be used between the plate and the pedestal. Leveling shall be effected by suitable means under the base of the pedestal.

5.2 The pedestal shall be 10 to 11 in. [250 to 275 mm] square at the top, and 15 to 16 in. [375 to 400 mm] square at the bottom, 25 to 30 in. [625 to 750 mm] in height, and shall be of monolithic construction, cast from concrete weighing at least 140 lb/ft<sup>3</sup> [2240 kg/m<sup>3</sup>]. A stable gasket cork padding,

½ in. [13 mm] thick and the same size as the pedestal bottom or four pieces of padding ½ in. [13 mm] thick and approximately 4 in. [100 mm] square, shall be inserted under the pedestal or the four corners, respectively. The flow table shall be checked frequently for levelness of the table top, stability of the pedestal, and tightness of the bolts and nuts in the table base and the pedestal table. (A torque of 20 lb-ft [27 N·m] is recommended when tightening those fastenings.)

5.3 The table top, after the frame has been mounted on the pedestal, shall be level along two diameters at right angles to each other, in both the raised and lowered positions.

## 6. Flow Table Lubrication

6.1 The vertical shaft of the table shall be kept clean and shall be lightly lubricated (see Note 4) with a light oil (SAE-10). Oil shall not be present between the contact faces of the table top and the supporting frame. Oil on the cam face will lessen wear and promote smoothness of operation. The table should be raised and permitted to drop a dozen or more times just prior to use if it has not been operated for some time.

NOTE 4—It has been demonstrated that an absence of lubrication on the table shaft will significantly reduce the flow reading.

## 7. Mold and Caliper

7.1 The conical mold for casting the flow specimen shall be of cast bronze or brass. The Rockwell hardness number of the metal shall be not less than 25 HRB. The height of the mold shall be 2.00 ± 0.02 in. [50.0 ± 0.5 mm]. The diameter of the top opening shall be 2.75 ± 0.02 in. [70.0 ± 0.5 mm] for new molds and 2.75 + 0.05 in. [70.0 + 1.3 mm] and -0.02 in. [-0.5 mm] for molds in use. The diameter of the bottom opening shall be 4.00 ± 0.02 in. [100.0 ± 0.5 mm] for new molds and 4.00 + 0.05 in. [+1.3 mm] and -0.02 in. [-0.5 mm] for molds in use. The surfaces of the base and top shall be parallel and at right angles to the vertical axis of the cone. The mold shall have a minimum wall thickness of 0.2 in. [5 mm]. The outside of the top edge of the mold shall be shaped so as to provide an integral collar for convenient lifting of the mold. All surfaces shall be machined to a smooth finish. A circular shield approximately 10 in. [255 mm] in diameter, with a center opening approximately 4 in. [100 mm] in diameter, made of nonabsorbing material not attacked by the cementitious mixture, shall be used with the flow mold to prevent mortar from spilling on the table top.

7.2 A caliper consisting of one fixed jaw and one jaw movable along a permanent scale shall be provided for measuring the diameter of the mortar after it has been spread by the operation of the table. The scale shall be machine divided into 40 increments with 0.16 in. [4.0 mm] between divisions with major division lines every five divisions and the increment number every ten divisions (Note 5). The construction and accuracy of the caliper shall be such that the distance between the jaws shall be 4 ± 0.01 in. [100 ± 0.25 mm] when the indicator is set at zero.

NOTE 5—The caliper is graduated to indicate one fourth of the actual flow percentage, so that the readings of four measurements on the caliper may be added to give the flow value without the necessity of calculating the average of four individual measurements of the total flow.

<sup>3</sup> Such a material can be obtained from the Cement and Concrete Reference Laboratory (CCRL), <http://www.ccrl.us>.

<sup>4</sup> Supporting data have been filed at ASTM International Headquarters and may be obtained by requesting Research Report RR:C01-1006. Contact ASTM Customer Service at [service@astm.org](mailto:service@astm.org).

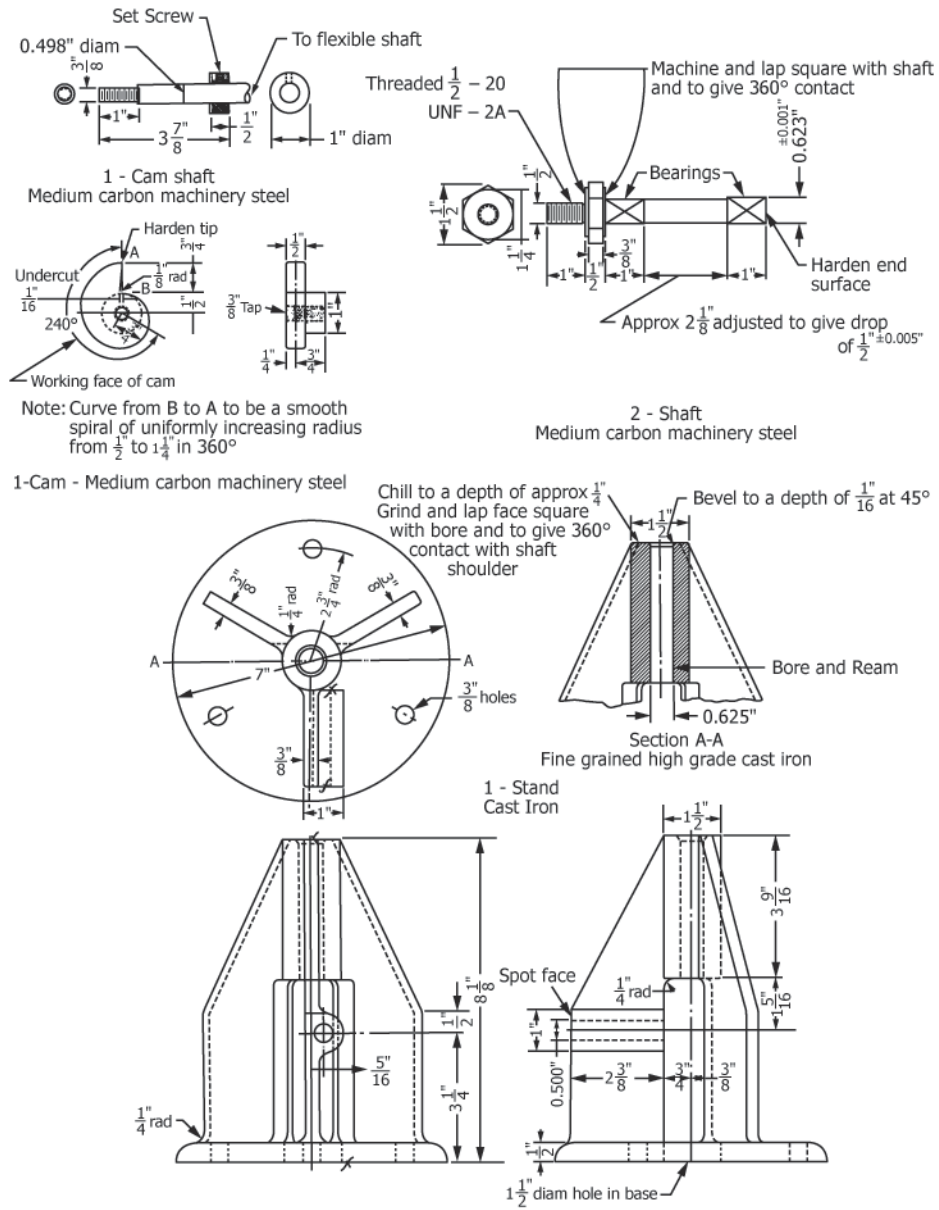

FIG. 1 Flow Table and Accessory Apparatus (Partial) (IP)